

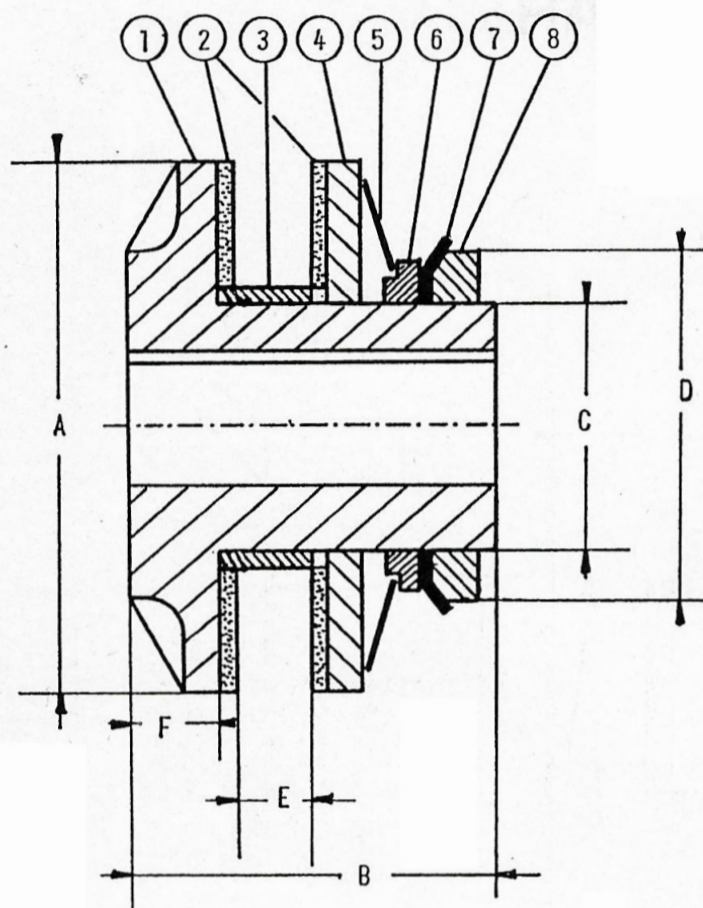

LIMITADOR DE PAR



- ① Núcleo central del mecanismo
- ② Disco de fricción (incorpora dos)
- ③ Casquillo
- ④ Plato de presión
- ⑤ Resorte muelle de disco
- ⑥ Arandela guía del resorte
- ⑦ Arandela de seguridad para la tuerca
- ⑧ Tuerca almenada de ajuste de presión

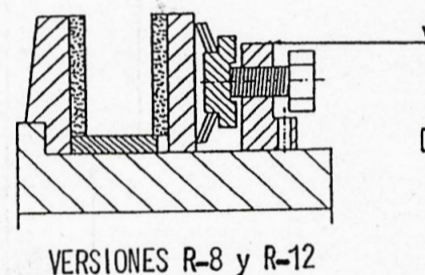

TABLA DE DIMENSIONES (MM) DE LIMITADORES DE PAR SERIE LIGERA

REFERENCIA	PAR mkg		DIAM. EJE			B	C	D	E MAX	F	PESO aprox. KG	LONGITUD CASQUILLO
	MIN.	MAX.	BRUTO	MAX	A							
	0,2 1	3 6	10	20	63	50	35	52	10	14	0,7	10-12-14
LIMIT 090	2	8	15	25	90	65	40	58	14	16	1,3	10-12-14-16
	3	18 25						78				
LIMIT 125	4	22	20	40	125	80	60	80	20	20	2,7	12-14-16-20
	8	45 60						108				
	10 20	60 120 145	25	65	175	110	95	125	30	25	7,8	14-16-20 22-24-28-30
								160				