

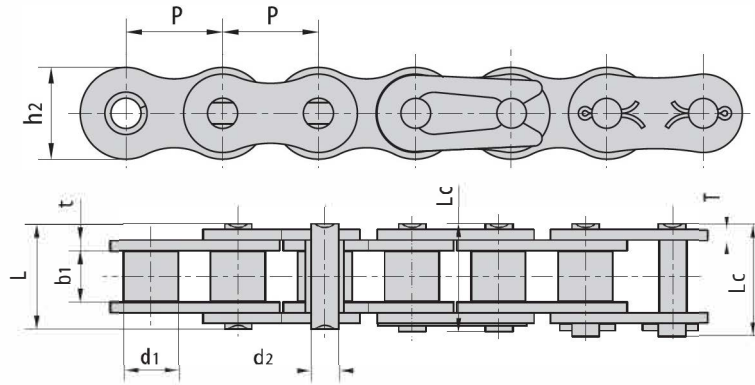

Cadenas anticorrosión Delta C&S simple.
 Simplex Dacromet-plate C&S chains.
 Chaînes de plaques simplex Dacromet C&S.



Codigo Code	Referencia Reference Référence	Paso Pitch Pas	Ø Rodillo Roller Roleau	Ancho interior Width inner Largeur intérieur	Ø Eje Pin Rouleau	Longitud eje Pin length Longueur axe		Ancho de malla Inner plate depth Largeur plaques	Espesor de malla Plate thickness Épaisseur plaques	Peso por metro Weight per meter Poids par mètre
		P mm	d1 max mm	b1 min mm	d2 max mm	L max mm	Lc max mm	h2 max mm	T max mm	q kg/m
	25DR	6.350	3.30	3.18	2.31	7.90	8.40	6.00	0.80	0.15
	35DR	9.525	5.08	4.77	3.58	12.40	13.17	9.00	1.30	0.33
	41DR	12.700	7.77	6.25	3.58	13.75	15.00	9.91	1.30	0.41
	40DR	12.700	7.95	7.85	3.96	16.60	17.80	12.00	1.50	0.62
	50DR	15.875	10.16	9.40	5.08	20.70	22.20	15.09	2.03	1.02
	60DR	19.050	11.91	12.57	5.94	25.90	27.70	18.00	2.42	1.50
	80DR	25.400	15.88	15.75	7.92	32.70	35.00	24.00	3.25	2.60
	100DR	31.750	19.05	18.90	9.53	40.40	44.70	30.00	4.00	3.91
	120DR	38.100	22.23	25.22	11.10	50.30	54.30	35.70	4.80	5.62
	140DR	44.450	25.40	25.22	12.70	54.40	59.00	41.00	5.60	7.50
	160DR	50.800	28.58	31.55	14.27	64.80	69.60	47.80	6.40	10.10
	04BDR	6.000	4.00	2.80	1.85	6.80	7.80	5.00	0.60	0.11
	05BDR	8.000	5.00	3.00	2.31	8.20	8.90	7.10	0.80	0.20
	06BDR	9.525	6.35	5.72	3.28	13.15	14.10	8.20	1.30	0.41
10042070	08BDR	12.700	8.51	7.75	4.45	16.70	18.20	11.80	1.60	0.69
10052070	10BDR	15.875	10.16	9.65	5.08	19.50	20.90	14.70	1.70	0.93
10062070	12BDR	19.050	12.07	11.68	5.72	22.50	24.20	16.00	1.85	1.15
10082070	16BDR	25.400	15.88	17.02	8.28	36.10	37.40	21.00	4.15/3.1	2.71
10102070	20BDR	31.750	19.05	19.56	10.19	41.30	45.00	26.40	4.5/3.5	3.70
	24BDR	38.100	25.40	25.40	14.63	53.40	57.80	33.20	6.0/4.8	7.10
	28BDR	44.450	27.94	30.99	15.90	65.10	69.50	36.70	7.5/6.0	8.50
	32BDR	50.800	29.21	30.99	17.81	66.00	71.00	42.00	7.0/6.0	10.25