

Cadenas de mallas juntas serie AL Leaf chains AL series Chaînes à mailles jointives série AL

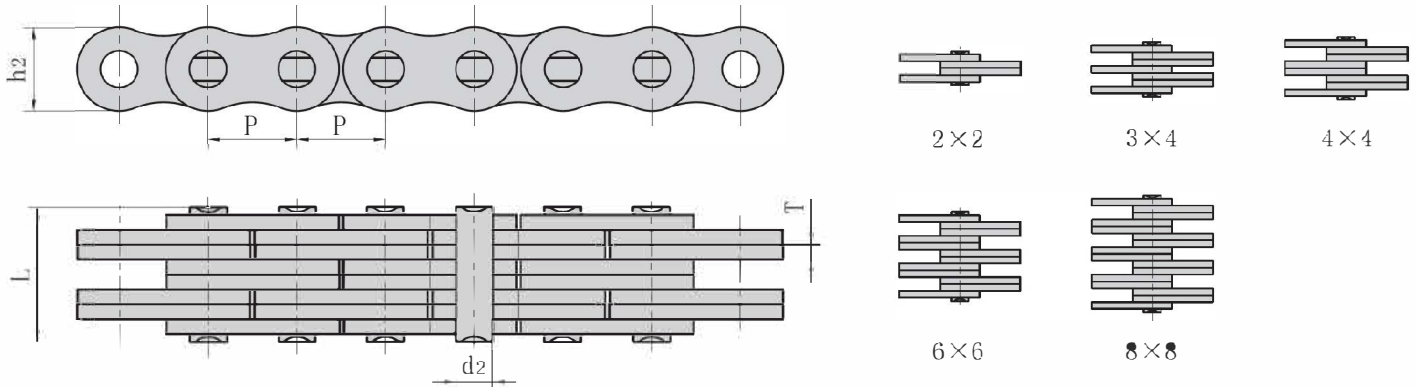

Código Code	Referencia Reference Référence	Paso Pitch Pas	Combinación mallas Plate lacing Combinaison plaques	Ancho malla Plate width Largeur plaques	Espesor malla Plate thickness Épaisseur plaque	Ø Eje Axe Rouleau	Longitud eje Pin length Longueur axe	Carga rotura Breaking load Charge rupture	Peso por metro Weight per meter Poids par mètre		
	ANSI	P mm	mm	h2 max mm	T max mm	d2 mm	L max mm	Q min kN/lbf	q kg/m		
18703522	AL322	9,525	2 x 2	7,7	1,3	3,58	6,8	9,0/2045	0,23		
18703544	AL344		4 x 4				11,6			18,0/4090	
18704022	AL422	12,7	2 x 2	10,4	1,5	3,96	8,3	14,7/3304	0,39		
18704044	AL444		4 x 4				14,4			29,4/6609	
18704066	AL466		6 x 1				20,5			44,0/9891	
18705022	AL522		2 x 2				11,05			24,5/5508	0,64
18705034	AL534	3 x 4	17	36,8/8273	1,1						
18705044	AL544	4 x 4	19,4	48,9/10993	1,25						
18705066	AL566	6 x 6	27,5	73,4/16500	1,79						
18706044	AL622	19,05	2 x 2	15,6	2,42	5,94	13	33,4/7508	0,86		
18706066	AL644		4 x 4				22,7			66,7/14994	1,76
18706066	AL666		6 x 6				32,2			100,1/22502	2,6
18706088	AL688		8 x 8				42,2			133,4/29988	3,49
18708044	AL822	25,4	2 x 2	20,8	3,25	7,92	16,2	57,9/13016	1,54		
18708066	AL844		4 x 4				29,4			115,7/26009	3
18708066	AL866		6 x 6				44,2			173,5/39003	4,46
18708088	AL888		8 x 8				55,5			231,4/52019	6,3
18710044	AL1022	31,75	2 x 2	25,6	4	9,53	19,6	84,5/18996	2,37		
18710066	AL1044		4 x 4				36,4			169,0/37991	4,68
18710066	AL1066		6 x 6				52,3			253,5/56987	7,2
18710088	AL1088		8 x 8				68,5			338,0/75982	9,94
18712044	AL1222	38,1	2 x 2	30,5	4,8	11,1	24,3	120,1/26998	3,65		
18712044	AL1244		4 x 4				43,8			240,2/53997	7,05
18712066	AL1266		6 x 6				63,2			360,3/80995	10,5
18712088	AL1288		8 x 8				82,6			480,4/107994	14,03
18714044	AL1444	44,45	4 x 4	36,4	5,6	12,64	51,3	302,5/68002	10,34		
18714066	AL1466		6 x 6				74,5			453,7/101992	15,16
18716044	AL1644	50,8	4 x 4	41,6	6,4	14,21	58	382,5/85986	12,98		
18716066	AL1666		6 x 6				83,8			573,8/128990	19,76
18716066	AL1688		8 x 8				109,5			765,0/171972	25,47

*** SI CON REFERENCIA NORMAL NO HAY EXISTENCIAS, BUSCAR CON LA MISMA REFERENCIA ACABADA CON LA LETRA "T"
EJEMPLO 18703522T**